

# DIAMOND<sup>®</sup>

DIAMOND CHAIN COMPANY



PIN OVEN ROLLER CHAIN 制罐运输滚子链

## DIAMOND PIN OVEN CHAIN 钻石制罐运输链

Diamond pin oven chains are built with Diamond standard series 60 pitch ANSI chain and are available with bendable, breakaway, or stainless steel carrier pins. Diamond pin oven chains are designed with carrier pins that are the actual chain pins, not an attachment, to improve the strength and integrity of the chain, and increase the overall life span of the chain.

制罐运输链是采用钻石链条公司ANSI 60标准系列的链条，可装配带有柔性、可分离或不锈钢的运载销。运载销不是附件，它与链条的销轴是一个整体，这样设计提高了链条的强度和整体性，增加了链条的寿命。

• **Bendable Pins:** Through-hardened medium carbon extended carrier pins are manufactured to produce a tough, ductile pin that is capable of withstanding incidental contact from jams or interference with machine framework. These pins are designed to be easily hand straightened back to their original position.

柔性销轴：经过穿透硬化的运载销，坚硬且有韧性，能经受住设备故障时发生的碰撞或与车壁的干涉，碰弯后可以很容易手动将这些销轴扳回原先的位置。

• **Breakaway Pins:** Case-hardened, low carbon extended carrier pins are manufactured to break off from incidental contact with jammed product, the machine frame, or other obstacles due to misalignment.

分离式销轴：表面硬化的运载销可从与堵塞的产品，车壁或其他物品的碰撞中分离开来。

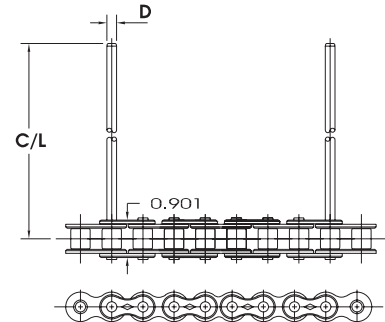

STANDARD PIN OVEN CHAIN 标准制罐运输链

ASME/ANSI 链号	Pitch 节距 mm	Roller Width 滚子长度 mm	Roller Diameter 滚子直径 mm	Pin Diameter 销轴直径 mm	Link Plate Thickness 链片厚度 mm	C	R	CL	每米重量 kg/m	Average Tensile Strength 平均拉伸载荷 KN
60	19.05mm	12.70mm	11.91mm	6.94mm	29.72mm	27.69mm	27.69mm	.....	1.475/0.23006	8500

C/L dimension will depend upon tip and pin extension selected. C/L尺寸根据选择的销帽和延伸销类型而定。

## DIAMOND RING LEADER® O-RING PIN OVEN CHAIN 钻石RING LEADER®带O型圈制罐运输链

Diamond RING LEADER pin oven chains are built with Diamond Chain's O-Ring technology to seal lubricant in and keep contaminants out at operating temperatures up to 450° F /232° C. RING LEADER pin oven chain can be provided with bendable, breakaway, or stainless steel carrier pins.

钻石RingLeader®系列的制罐运输链采用了钻石链条公司O型圈技术，将润滑剂密封在O型圈里面，防尘，工作温度可高达232。钻石Ring Leader®带O型圈制罐运输链也可装配带柔性，可分离或不锈钢的运载销。

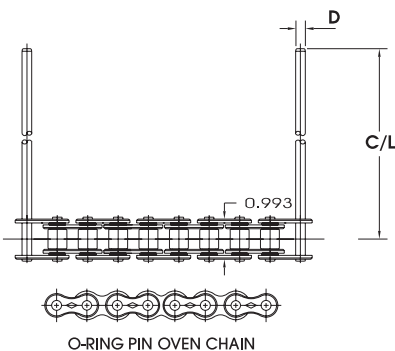
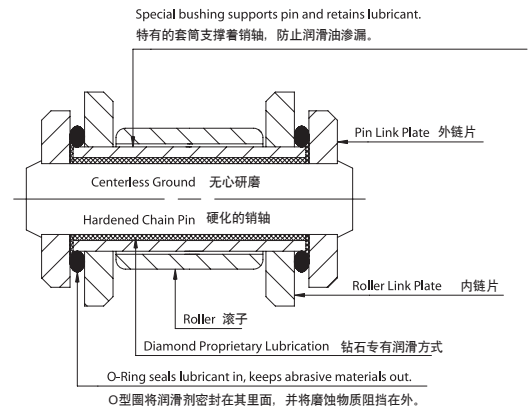

O-RING PIN OVEN CHAIN

Diamond Number	Pitch 节距 mm	Roller Width 滚子长度 mm	Roller Diameter 滚子直径 mm	Pin Diameter 销轴直径 mm	Link Plate Thickness 链片厚度 mm	C	R	C/L	每米重量 kg/m	Average Tensile Strength 平均拉伸载荷 KN
50XL0	19.53mm	9.53mm	10.16mm	5.08mm	2.032mm	24.13mm	22.61mm	.....	1.07 kg/m	6500
60XL0	19.05mm	12.70mm	11.91mm	6.94mm	29.72mm	29.72mm	27.69mm	.....	1.50 kg/m	7700

C/L dimension will depend upon tip and pin extension selected. C/L尺寸根据选择的销帽和延伸销类型而定。

# DIAMOND PIN OVEN CHAIN TIP ASSORTMENT

## 钻石制罐运输链销帽分类

Diamond Chain produces over fifty different tips and pin extensions for use with pin oven chain. These tips are available in a variety of materials including steel, aluminum, heat stabilized nylon and Diamond Chain's proprietary high temperature PEEK™ which is designed to withstand higher temperatures without drying, cracking, or wearing out. The following are the most common tips, additional tip and pin extension information can be found by contacting the Diamond Chain Company.

钻石链条可生产50种以上不同的销帽或延伸销配合制罐运输链使用。材质有多种选择包括钢，铝，热稳定型尼龙和钻石链条公司特有的高温PEEK®材料，此材质耐高温，不会干化，破裂或磨损。下图为最常见的销帽类型，其他类型请联系钻石链条公司进行咨询。

	1	2	3	4	5	6	7	8
D	5.94mm	6.27mm	5.46mm	11.89mm	14.61mm	8.94mm	22.23mm	(20.83mm)
H	N/A	25.40mm	16.51mm	8.89mm	11.99mm	8.89mm	25.40mm	(25.40mm)
R	2.97mm	N/A	N/A	N/A	7.62mm	N/A	45 deg.	(3.18mm)

Tip 8 is highlighted with a callout box: **Features Diamond Chains PEEK® Tip 钻石链条特有的PEEK®销帽**

Tips 1-7 are made to order. Tip 8 is in stock. 1-7种销帽类型需定制。8号销帽有存货。

## DIAMOND PIN REPLACEMENT 钻石销轴的更换

Diamond pin oven chains are designed without the swaged pin heading so that if a link should need to be repaired, it can be done quickly and easily without grinding pins. Start by removing the air pressure in the tension device and clamp the chain in place. Use a pin extractor to remove the pin link and replace with a repair link. The chain is then ready to resume production.

钻石制罐运输链在设计时没有在销轴的一端锻造模形头，所以当需要更换/维修销轴时，无需打磨销轴就可很快很轻松地更换下销轴。更换时先解除张紧装置的气压，将链条固定好，用销轴拔取装置将销轴取出，换上新的销轴。链条即准备好恢复生产。

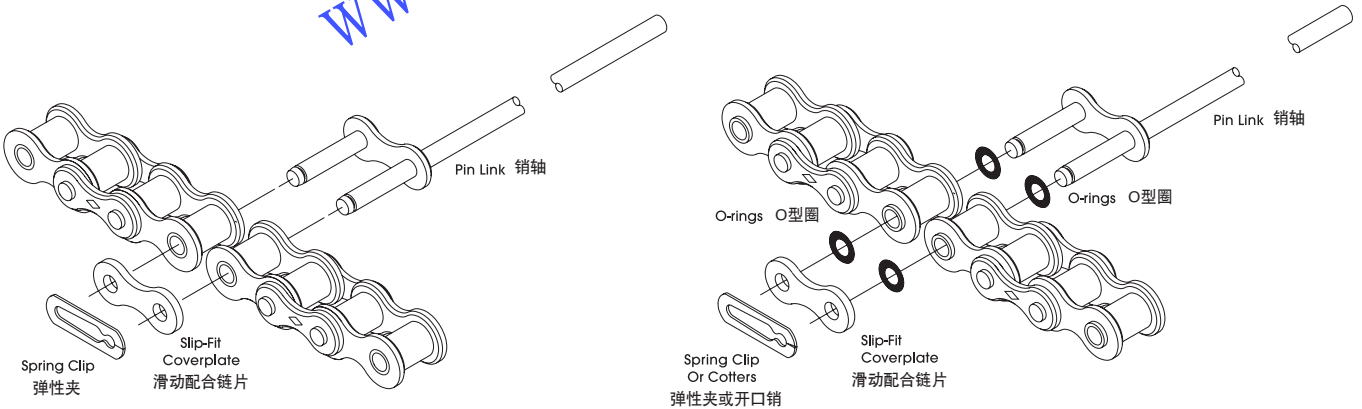

## ORDERING INSTRUCTIONS 订购说明

**Ordering Instructions:** Use the above drawing showing available tips and specify whether Standard or RING LEADER base chain is desired, type of pin material (bendable, breakable or stainless), type of tip configuration and the extension from the **centerline** of the chain to the end of the pin including the tip.

订购说明：根据上述图纸中的销帽，说明需要标准系列还是Ring Leader®系列的链条，销轴材质（柔性，可分离或不锈钢），销帽形状和从链条中心线到销帽末端的长度。

\*PEEK is a trademark of Amoco Performance Products, Inc. . \*PEEK为美国阿莫科公司的一个商标